

WYMIARY: BR.375_S_B_12

TYP	D	B1	BAN	B max	Waga [kg]
BR.375_S_B_12	2045	375	2250	2430	279

WYMIARY: BR.375_S_E_10

TYP	D	B1	BAN	B-Ex	Waga [kg]
BR.375_S_E_10	2045	375	1875	1875	217

BR.375_S_B_12

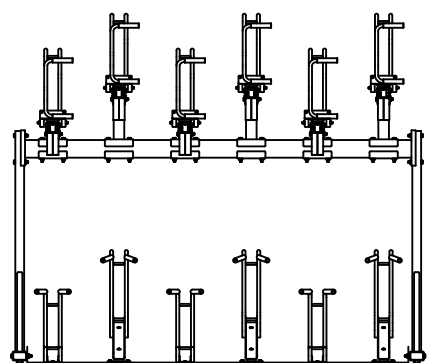

BR.375_S_E_10

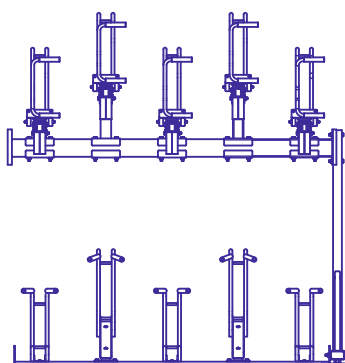

BR.375_S_B_12 + BR.375_S_E_10 = BR.375_S_22

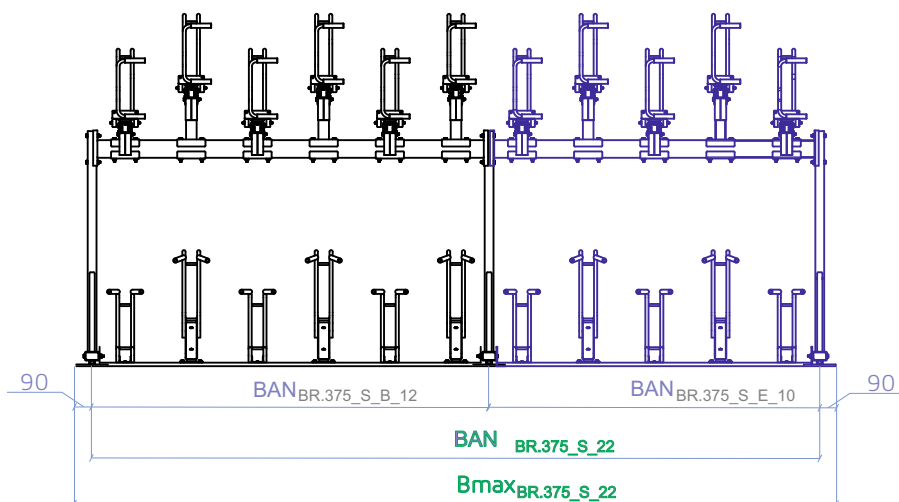

$$BAN_{BR.375_S_B_12} = 2250 \text{ mm}$$

$$BAN_{BR.375_S_E_10} = 1875 \text{ mm}$$

$$BAN_{BR.375_S_22} = BAN_{BR.375_S_B_12} + BAN_{BR.375_S_E_10} = 2250 + 1875 = 4125 \text{ mm}$$

$$Bmax_{BR.375_S_22} = BAN_{BR.375_S_B_12} + BAN_{BR.375_S_E_10} + 90 + 90 = 2250 + 1875 + 90 + 90 = 4305 \text{ mm}$$

$$Waga_{BR.375_S_22} = Waga_{BR.375_S_B_12} + Waga_{BR.375_S_E_10} = 279 + 217 = 496 \text{ kg}$$

WYMIARY: BR.375_S_22

TYP	D	B1	BAN	B max	Waga [kg]
BR.375_S_22	2045	375	4125	4305	496

WYMIARY: BR.375_S_B_16

TYP	D	B1	BAN	B max	Waga [kg]
BR.375_S_B_16	2045	375	3000	3180	356

WYMIARY: BR.375_S_E_16

TYP	D	B1	BAN	B-Ex	Waga [kg]
BR.375_S_E_16	2045	375	3000	3000	334

WYMIARY: BR.375_S_E_10

TYP	D	B1	BAN	B-Ex	Waga [kg]
BR.375_S_E_10	2045	375	1875	1875	217

BR.375_S_B_16

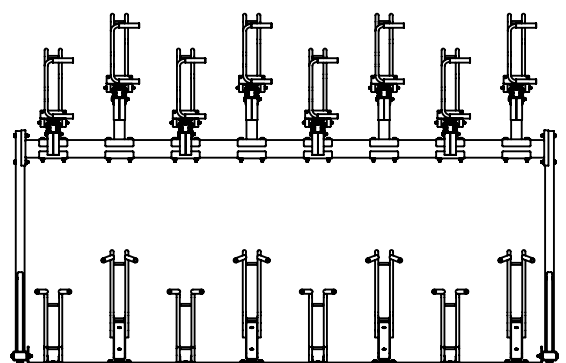

BR.375_S_E_16

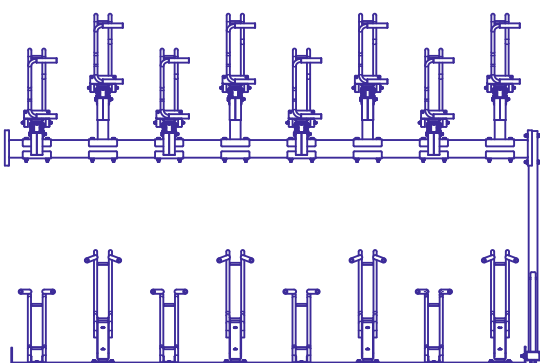

BR.375_S_E_10

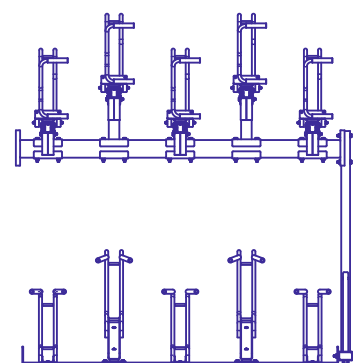

$$\text{BR.375_S_B_16} + \text{BR.375_S_E_16} + \text{BR.375_S_E_10} = \text{BR.375_S_42}$$

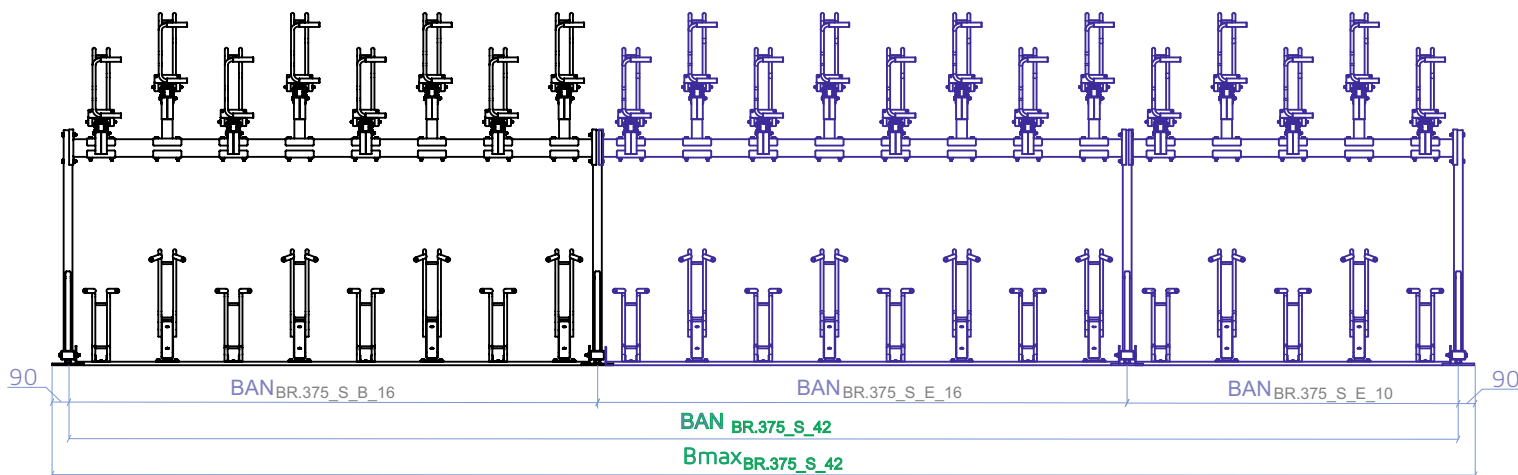

$$\text{BAN}_{\text{BR.375_S_B_16}} = 2250 \text{ mm}$$

$$\text{BAN}_{\text{BR.375_S_E_16}} = 1875 \text{ mm}$$

$$\text{BAN}_{\text{BR.375_S_E_10}} = 1875 \text{ mm}$$

$$\text{BAN}_{\text{BR.375_S_42}} = \text{BAN}_{\text{BR.375_S_B_16}} + \text{BAN}_{\text{BR.375_S_E_16}} + \text{BAN}_{\text{BR.375_S_E_10}} = 3000 + 3000 + 1875 = 7875 \text{ mm}$$

$$\text{Bmax}_{\text{BR.375_S_42}} = \text{BAN}_{\text{BR.375_S_B_16}} + \text{BAN}_{\text{BR.375_S_E_16}} + \text{BAN}_{\text{BR.375_S_E_10}} + 90 + 90 = 3000 + 3000 + 1875 + 90 + 90 = 8055 \text{ mm}$$

$$\text{Waga}_{\text{BR.375_S_42}} = \text{Waga}_{\text{BR.375_S_B_16}} + \text{Waga}_{\text{BR.375_S_E_16}} + \text{Waga}_{\text{BR.375_S_E_10}} = 356 + 334 + 217 = 907 \text{ kg}$$

WYMIARY: BR.375_S_42

TYP	D	B1	BAN	B max	Waga [kg]
BR.375_S_42	2045	375	7875	8055	907

